

## TFSR 315 L ROOF FAN BLACK

Item number 1343

### Description

- Swing-out
- Speed-controllable
- Easy to install
- Reliable

The TFSR range consists of roof fans with circular connection and are fitted with a single-inlet centrifugal fan with backward-curved blades and external rotor motors. The motors can be tilted outwards to facilitate inspection and service. They have integral on/off switch and are supplied with 1 m cable for fast connection to the mains e.g. via the connection box on the roof curb TOB or TOS.

These fans are suitable for exhaust-air ventilation systems, e.g. single and multiple dwellings, offices and day nurseries. To protect the motors from overheating, all motors have an integral thermal contact with electrical reset. The fans are manufactured in powder-coated, galvanized sheet steel and are delivered in the standard colours of black or brick red.

TFSR is delivered with a spigot connection if the installation requires direct duct connection. TFSR 125-160 are delivered with a Ø 160 spigot and TFSR 200-315 with a Ø 200. The spigot is not pre-assembled to the fan.



### Technical parameters

Parameter	Value	Unit
Voltage	230	V
Frequency	50	Hz
Phase	1	~
Power	329	W
Current	1,43	A
Max. airflow	1 598	m <sup>3</sup> /h
R.p.m.	2 401	r.p.m.
Min. static back pressure	0	Pa
Max. temperature of transported air	42,2	°C
Max. temperature of transported air when speed-controlled	38	°C
Sound pressure level at 10 m	53	dB(A)
Weight	8,6	kg
Insulation class, motor	F	
Enclosure class, motor	44	IP
Capacitor	8	µF

## Diagrams

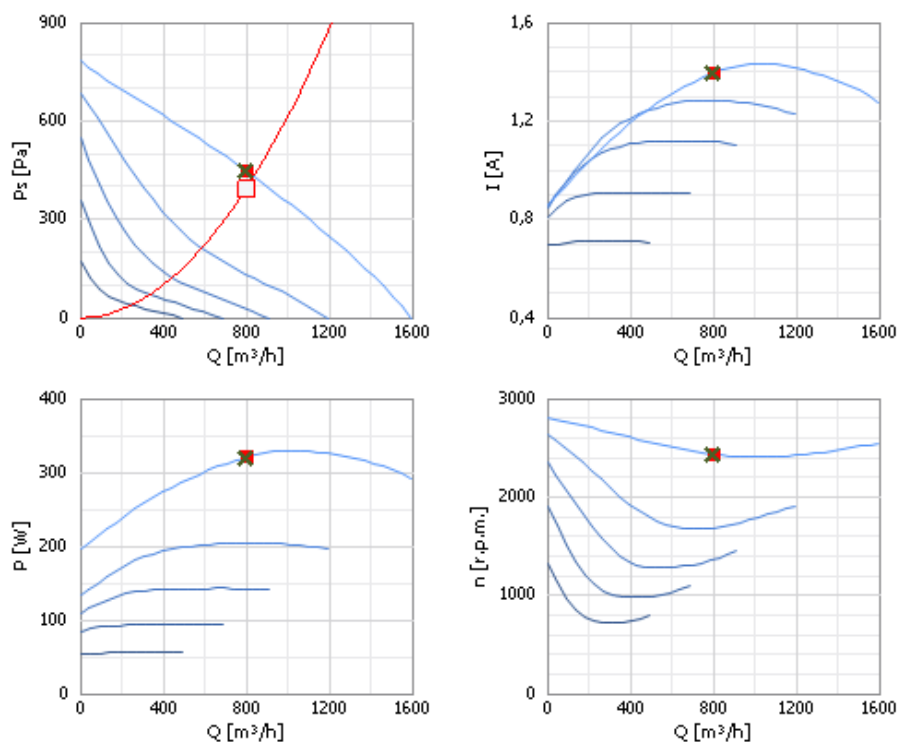

### Max. efficiency data

✘ Working point							
Q [m³/h]	Ps [Pa]	P [W]	n [r.p.m.]	I [A]	U [V]	SFP [kW/m³/s]	E [%]
799	450	320	2432	1,39	230	1,44	31,2

	Mid frequency band								Tot
	63	125	250	500	1k	2k	4k	8k	
Inlet Lw dB(A)	51	70	68	75	71	67	63	54	78
Outlet Lw dB(A)	37	62	65	82	79	73	64	57	84

### Product selection data

☐ Selected point		■ Working point							
Q [m³/h]	Ps [Pa]	Q [m³/h]	Ps [Pa]	P [W]	n [r.p.m.]	I [A]	U [V]	SFP [kW/m³/s]	E [%]
800	390	800	449	320	2432	1,39	230	1,44	31,2

	Mid frequency band								Tot
	63	125	250	500	1k	2k	4k	8k	
Inlet Lw dB(A)	51	70	68	75	71	67	63	54	78
Outlet Lw dB(A)	37	62	65	82	79	73	64	57	84

## Dimensions

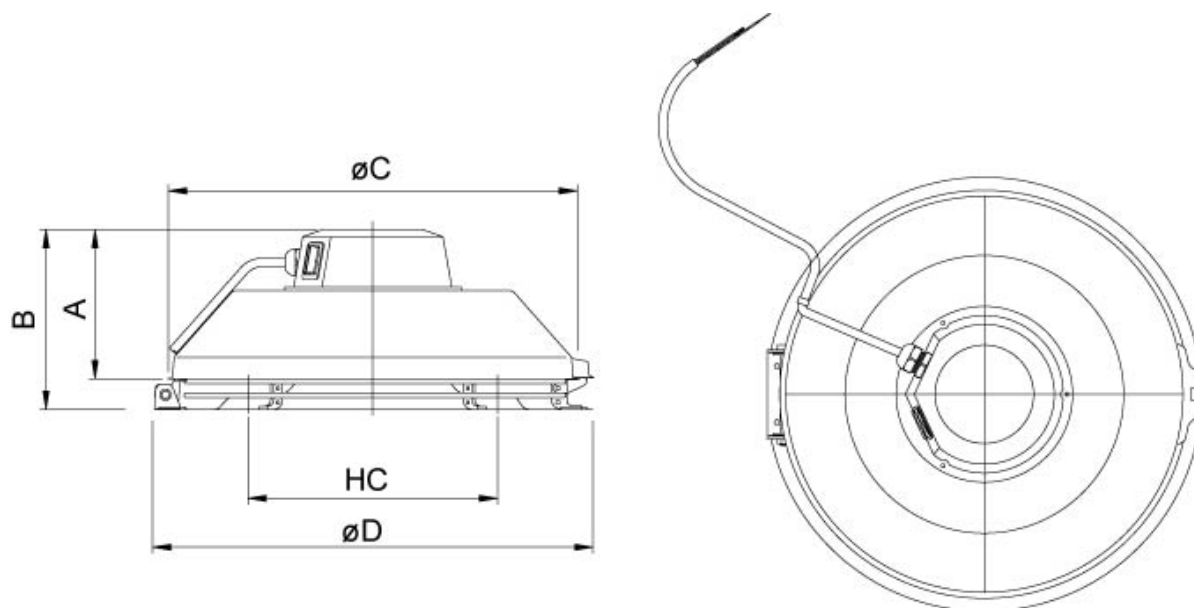

TFSR	A	B	øC	øD	HC
315M/L	160	206	404	485	250

HC = Hole diameter for fixing, ø6x4

Wiring

...

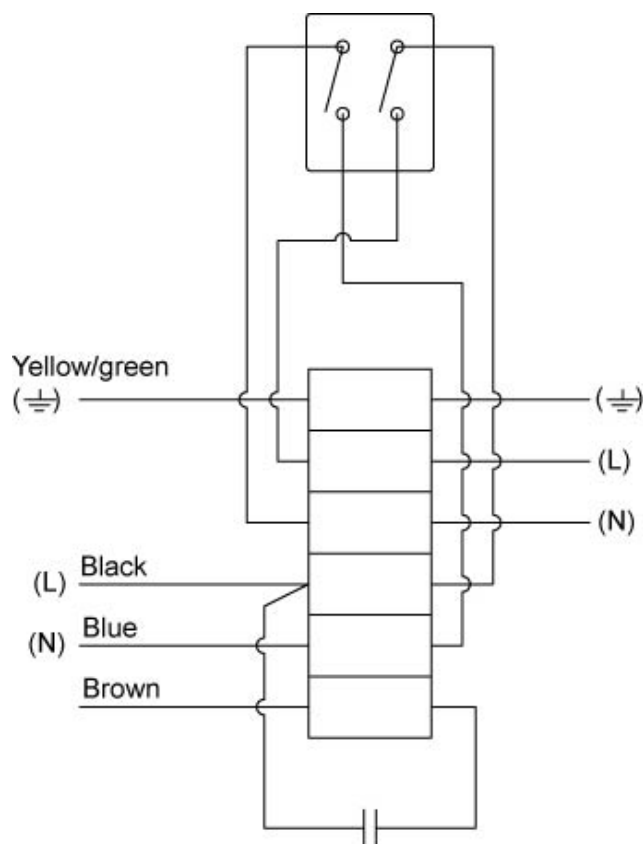

## Accessories

### Electric accessories

- C04D Thermostat -35... +20 C
- CO2 Transmitter /CO2RT-R-D
- DTV500-OEM incl connection kit
- ETFV MINI Speed control
- F251-16-60 Cookerhood transf
- HR1 Room Humidistat IP21
- MicroREX D21 Plus Time Switch
- Presence detector/IR24-P
- RE 1,5 Speed control
- REE 2 Speed control
- REPT 6 Digital regulator
- RETP 6 Temp/Pressure regulator
- REU 1.5 Speed control
- RT 0-30 Room Thermostat
- T 120 Timer

### Accessories

- LDC 200-600 Silencer
- LDC 200-900 Silencer
- RSK 200 Back draft damper
- TOB 200-315 Roof curb Black
- TOS 200-315 Roof curb Black